

## MOTOR DATASHEET – 1500W 24V

### CARATTERISTICHE

Grandezza	Ø 110 mm
Potenza	1500 W S2
Campo	4 espansioni polari
Cuscinetti	Cuscinetti a sfere
Alimentazione	24 Vcc
Spazzole	4 spazzole rame-grafite
Cavo alimentazione	3 terminali

Tipo	S	Pn (W)	V (V)	I (A)	IC	FF	Mn (Nm)	n <sub>1</sub> (min <sup>-1</sup> )	IP	Kg
<b>EMF102400000</b>	S2	1500	24	150	F	1	7	2700	44	7,0

### DIMENSIONI

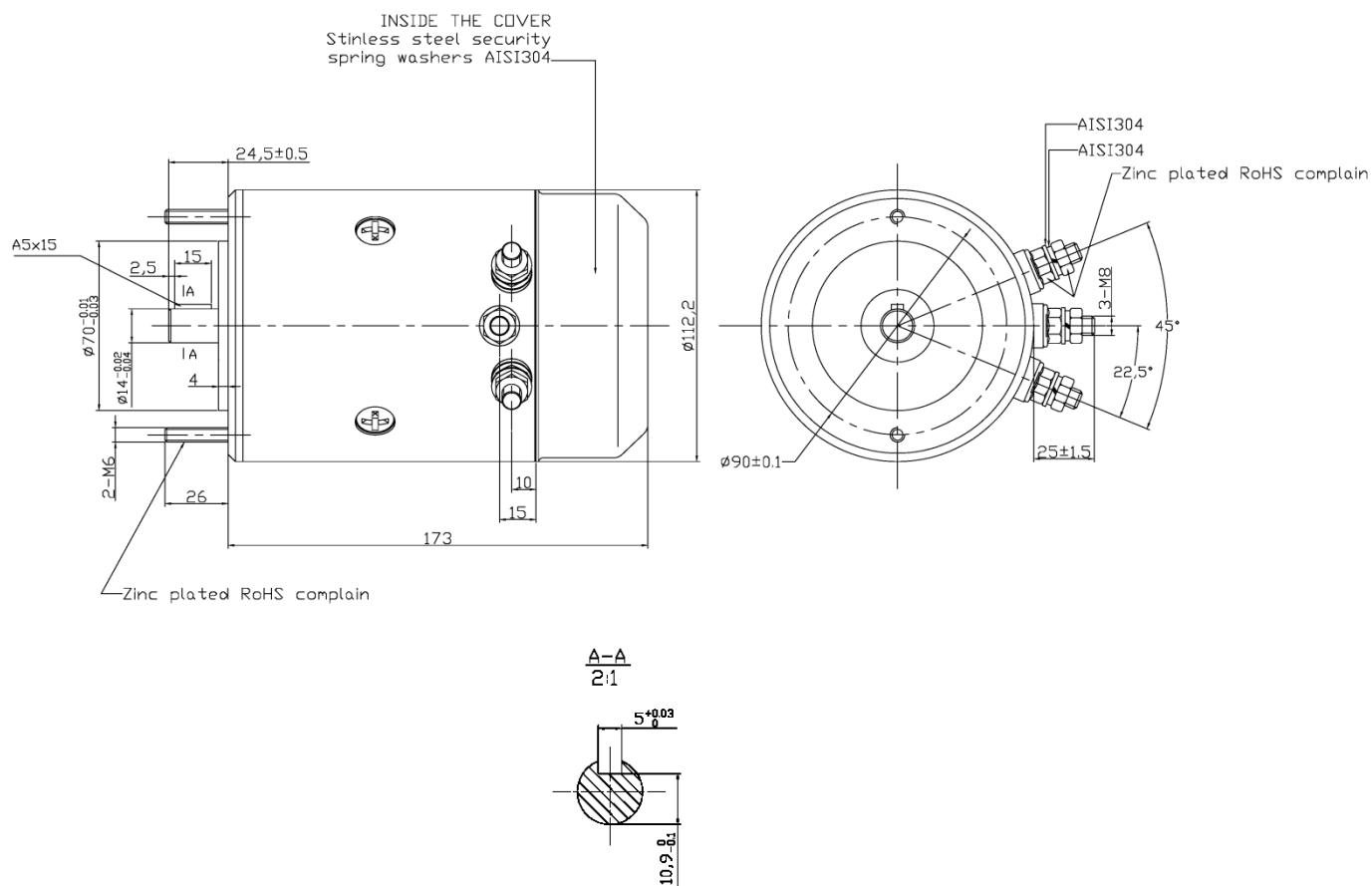

[www.quickitaly.com](http://www.quickitaly.com)

Quick S.p.A. - Via Piangipane 120/A - 48124 Piangipane (RA) ITALY - Tel. +39 0544 415 061 - Fax +39 0544 415 047 - e-mail [quick@quickitaly.com](mailto:quick@quickitaly.com)  
P. IVA IT 01216790392 - R.E.A. RA 128813 - Cod. Fisc. / Reg. Imp. Ravenna 02181450400 - Cap. Soc. I.V. € 1.150.000,00 - RAEE n° IT11090000007294  
Società soggetta a direzione e coordinamento di Quick Holding S.p.A.