

QR CLUTCHES

Quick Release & Double V-Grip

User's guide

Date 10/2020 Rev. 03

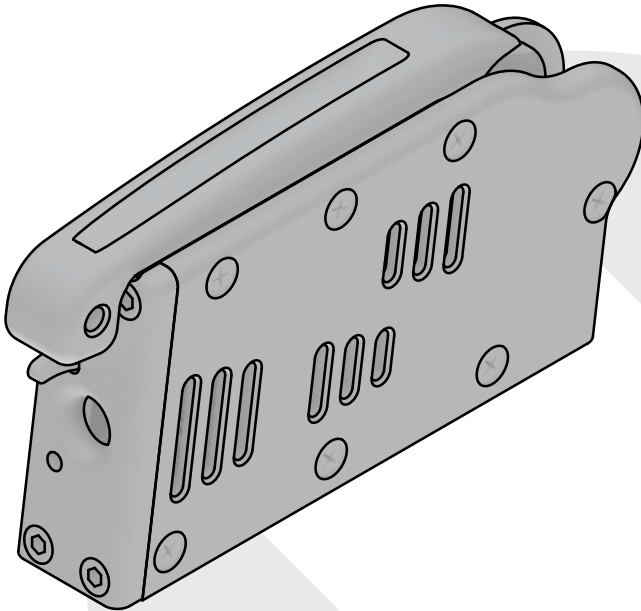

MODELS

506.101
506.103
506.106
506.121
506.123
506.126
506.141
506.143
506.146

antal

Installation manual for Antal Quick Release & Double V-Grip

Contents

- QR Clutches p. 1
- Maintenance p. 3
- Mounting p. 4
- Mounting Set p. 5
- Exploded View p. 7



The new Antal QR clutch allows to release a line under maximum load, you can open the handle and release the line without the aid of a winch.

DOUBLE V-GRIP

The DV-grip is a locking system based on two opposing V shaped wedges, the result is a 4 sided grip which provides the following benefits over traditional 2-sides-lock clutches:

- Less line wear
- Higher holding power
- Smaller sizes and lower weight



DOUBLE V-GRIP

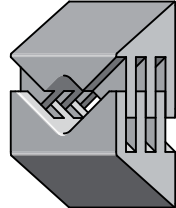

DV-Grip is an Antal patent.

QR RANGE

Three models for 10, 12 and 14 mm lines are available. Each model is suitable for a specific line diameter which is printed on the rear side.

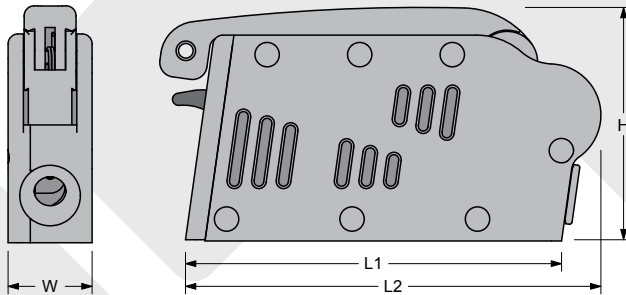

QR CLUTCHES							
MODEL	FOR LINE Ø mm	W mm	L1 mm	L2 mm	H mm	WEIGHT kg*	MAX LOAD kg
506.101	10	34	154	170	96	1,00	1600
506.121	12	37	176	193	101	1,35	2200
506.141	14	40	203	222	109	1,70	3000

Mounting fasteners, 3 threaded studs, washers and nuts are included. (AISI.316 material)

*Mounting not included in the weight

MAXIMUM LOAD

The Maximum load values are based on load tests made on **Dyneema™** and polyester lines with different covers. **Dyneema™** lines with a Kevlar-polyester cover provided much better results than **Dyneema™** lines with polyester cover which performed poorly, the test results were even below those of a simple polyester line (polyester core and cover). The Max Load is a limit for the line not for the clutch. Appropriate safety margins must be observed at maximum loads.

OPENING AND LOCKING

The clutch can be opened by lifting the handle, the handle can be pushed back down and the **“FREE”** indicator is now exposed, lines can now run freely inside the clutch. To move from **FREE** to **LOCK** a line just push the lock lever to release the jaws, it will lock the line and the **FREE-line mark** will disappear. This clutch can be opened even under high load.

CAUTION !

Opening the clutch under high load has to be done with utmost care! One must be aware of the danger of the initial load on the now free-running line. Make sure that anyone near the clutch is well clear of the line and is aware that the quickly free-running line can cause bodily harm and can damage parts of a boat.

RECOVER AND TENSION THE LINE

It is possible to recover the line in both the **FREE** or **LOCKED** position. To reduce friction and line wear we recommend to tail a line in the **FREE** position. After tensioning and before taking the line off the winch check the position of the **FREE line-mark**, if it is visible then lift the Lock Lever, the jaws will lock the line and the **FREE-line mark** will disappear. When the **FREE line-mark** is not visible, the line is locked and you can take the line off the winch.

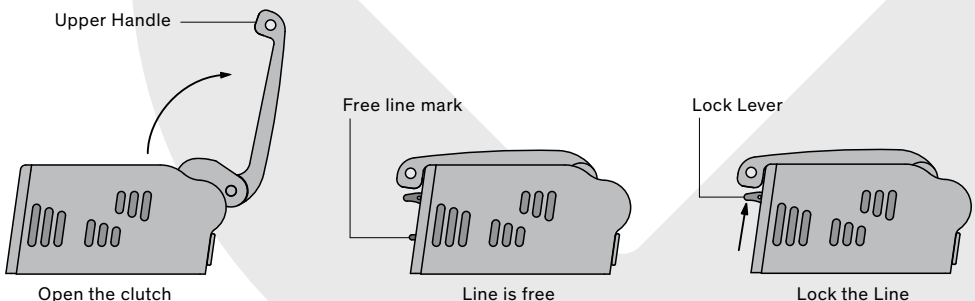

Antal clutches do not need any lubrication, but washing with fresh water will prolong the life of the clutch and ensure a reliable operation.

There are some slots on the side cheeks of the QR clutch through which fresh water can be sprayed for a quick and easy cleaning.

DISASSEMBLY

Disassembling and reassembling must be performed by a qualified technician. A QR clutch can be opened for a thorough and complete cleaning in the following way:

- 1 – Open the clutch handle to reduce the pressure on the inner springs.
- 2 – Remove the 4 screws and take off the Rear Cover.
- 3 – Close the clutch handle.
- 4 – Remove the internal mechanism.

After maintenance on the internal mechanism is completed and put back in place, open the clutch handle again, then mount the rear cover. The QR clutch is now ready for operation again.

To avoid aluminium corrosion, use a light grease or a product like Tef-Gel to reduce contact between aluminium and stainless steel parts (screws). It is important to avoid any kind of lubrication on the V-shaped area of the two wedges. Spilling a lubricant on the wedges will result in reduced performance of the clutch! For lubrication and aluminium protection Antal offers **Hidrolube** grease in 150 gr packs.

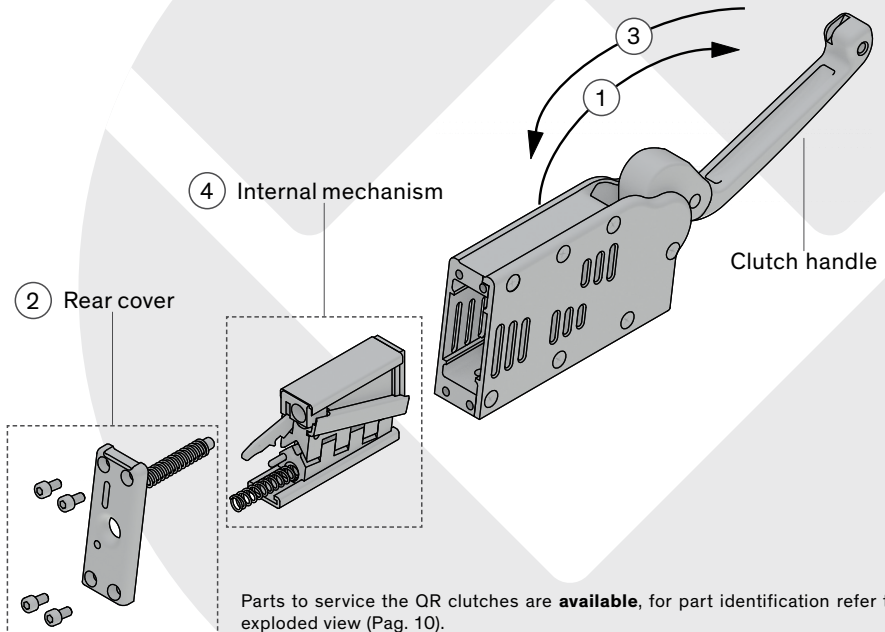

Parts to service the QR clutches are **available**, for part identification refer to the exploded view (Pag. 10).

POSITIONING

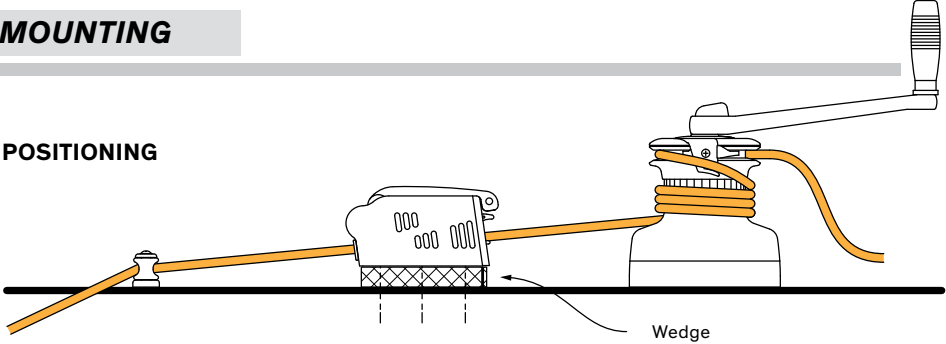

The clutch should be mounted in such a position that a fair lead of the line from the clutch to a winch is maintained. If that is not the case then friction of the line on the clutch exit may cause excessive wear on the line.

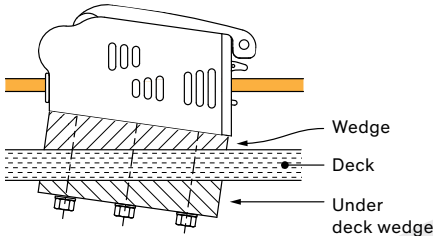

A wedge under clutch may correct the misalignment between the exit of the clutch and entrance of the line onto drum of the winch. If the wedge has a significant angle then an under-deck wedge may be necessary to counter the on-deck angle.

FASTENING BY STUDS

The clutch is mounted from under deck with three threaded studs, washers and nuts, made of AISI316 stainless steel, all hardware is included.

STUD LENGTH

Cut the studs to obtain the right length on the base of the deck thickness :

$L = \text{deck thickness} + 22 \text{ mm}$ for 8 mm studs

$L = \text{deck thickness} + 28 \text{ mm}$ for 10 mm studs

THREAD LOCKER

Use Loctite® strong (270) or medium (243) to secure the studs in the clutch base, use Loctite® medium (243) or weak (222) on the studs and the nuts under-deck.

HOLES FOR THROUGH DECK MOUNTING

A QR clutch is mounted with three studs, three holes need to be drilled through the deck. Use the templates on page 7 to drill the holes in the correct location.

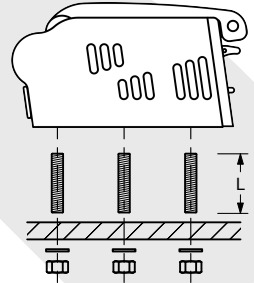

CAUTION !!

Before drilling the holes make sure that location of the deck is structurally sound and strong enough to accept the high load of a QR clutch!

Cored mounting surfaces may have to be re-inforced with an epoxy filler, a backing plate of appropriate size and thickness may also be necessary!

SEALANT

Put a flexible and waterproof sealant around the holes on deck and under the base of the clutch to prevent water ingress

QR WITH MOUNTING BASE

When it is not possible to access the mounting studs from the bottom side of the QR clutch, for example when mounting on a mast, Antal offers a QR clutch with a special **mounting base**. This model will be fixed with 2 screws (Allen screws ISO 7380 included) from above into threaded holes.

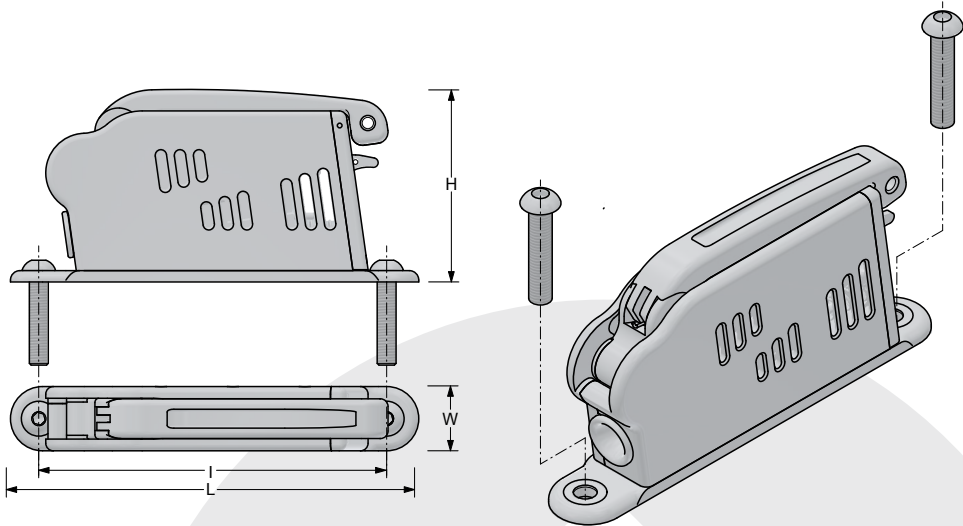

MOUNTING SET: LOWER BASE

QR MODEL	L mm	W mm	H mm	I mm	WEIGHT kg*	FASTENERS N x Ø mm	BASE ONLY MOD.
506.106	216	34	102	184	1,12	2 x Ø10	Y-SA027
506.126	249	37	109	210	1,52	2 x Ø12	Y-SA029
506.146	280	40	117	238	2,10	2 x Ø12	Y-SA051

*Mounting not included in the weight.

SIDE MOUNTING QR

For side mounting Antal offers a QR clutch with a special base that will be fixed to the deck with 3 threaded studs (316 studs, nuts and washers are included). The same base is suitable for both the left and the right version.

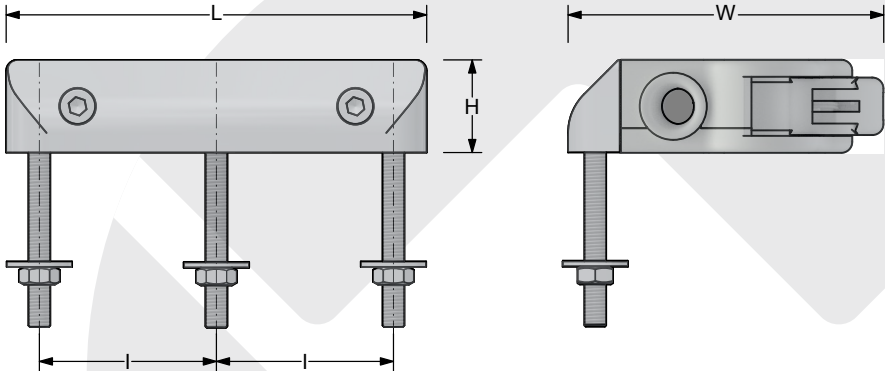
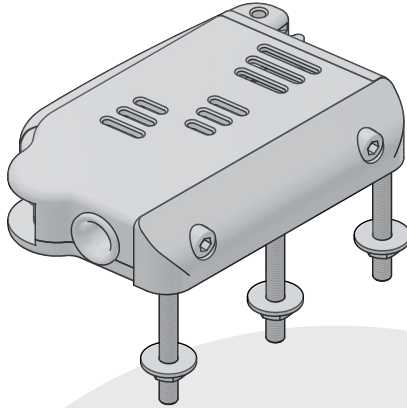

MOUNTING SET: LATERAL BASE

QR MODEL	L mm	H mm	W mm	I mm	WEIGHT kg*	FASTENERS N x Ø mm	BASE ONLY MOD.
506.103	154	34	115	65	1,14	3 x Ø8	Y-SA028
506.123	176	37	125	74	1,54	3 x Ø10	Y-SA030
506.143	203	40	133	87	1,90	2 x Ø12	Y-SA052

*Mounting not included in the weight

QR10 MOD. 506.101

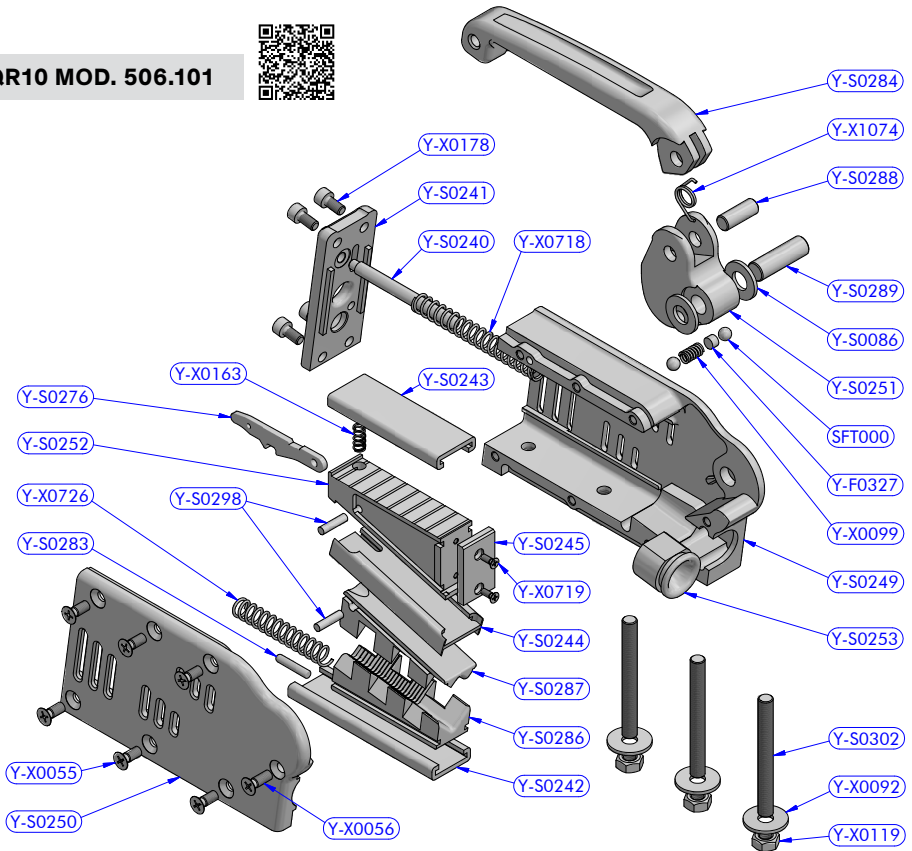

CODE	DESCRIPTION	MATERIAL	Q.TY
SFT000	Torlon ball 1/4"	Plastic	2
Y-F0327	Teflon pin	Teflon	1
Y-S0086	Platic washer	Plastic	2
Y-S0240	Wedge spring pin	S.Steel	1
Y-S0241	Rear cover	Aluminium	1
Y-S0242	Lower guide	Polietilene	1
Y-S0243	Upper guide	Polietilene	1
Y-S0244	Middle guide	Polietilene	1
Y-S0245	Pad	Composite fibre	1
Y-S0249	Body	Aluminium	1
Y-S0250	Cheekplate	Aluminium	1
Y-S0251	Cam	Aluminium	1
Y-S0252	Wedge	Aluminium	1
Y-S0253	Ring	Aluminium	1
Y-S0276	Lock lever	S.Steel	1
Y-S0283	Free line mark	Aluminium	1
Y-S0284	Lever	Aluminium	1

CODE	DESCRIPTION	MATERIAL	Q.TY
Y-S0286	Lower jaw	Aluminium	1
Y-S0287	Upper jaw	Aluminium	1
Y-S0288	Spindle	S.Steel	1
Y-S0289	Spindle	S.Steel	1
Y-S0298	Pin	S.Steel	2
Y-S0302	Stud	S.Steel	3
Y-X0055	Screw	S.Steel	6
Y-X0056	Screw	S.Steel	1
Y-X0092	Washer	S.Steel	3
Y-X0099	Compression spring	S.Steel	1
Y-X0119	Nut	S.Steel	3
Y-X0163	Compression spring	S.Steel	1
Y-X0178	Screw	S.Steel	4
Y-X0718	Compression spring	S.Steel	1
Y-X0719	Screw	S.Steel	2
Y-X0726	Compression spring	S.Steel	1
Y-X1074	Torsion spring	S.Steel	1

QR12 MOD. 506.121

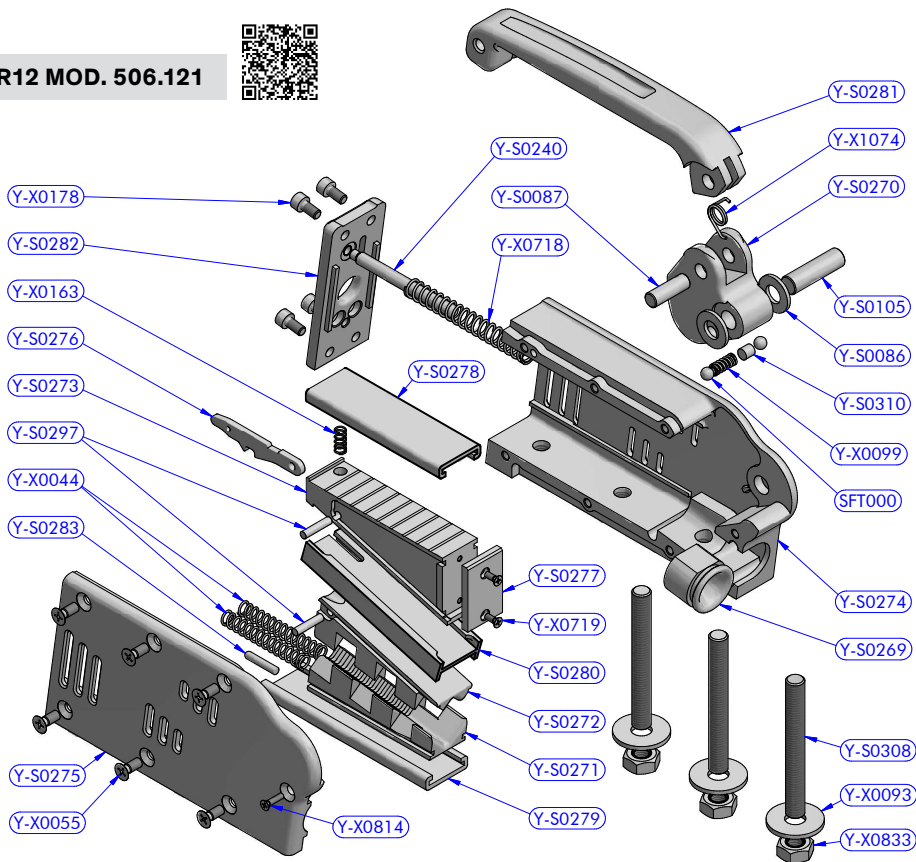

CODE	DESCRIPTION	MATERIAL	Q.TY
SFT000	Torlon ball 1/4"	Plastic	2
Y-S0086	Platic washer	Plastic	2
Y-S0087	Spindle	S.Steel	1
Y-S0105	Spindle	S.Steel	1
Y-S0240	Wedge spring pin	S.Steel	1
Y-S0269	Ring	Aluminium	1
Y-S0270	Cam	Aluminium	1
Y-S0271	Lower jaw	Aluminium	1
Y-S0272	Upper jaw	Aluminium	1
Y-S0273	Wedge	Aluminium	1
Y-S0274	Body	Aluminium	1
Y-S0275	Cheekplate	Aluminium	1
Y-S0276	Lock lever	S.Steel	1
Y-S0277	Pad	Composite fibre	1
Y-S0278	Upper guide	Polietilene	1
Y-S0279	Lower guide	Polietilene	1
Y-S0280	Middle guide	Polietilene	1

CODE	DESCRIPTION	MATERIAL	Q.TY
Y-S0281	Lever	Aluminium	1
Y-S0282	Rear cover	Aluminium	1
Y-S0283	Free line mark	Aluminium	1
Y-S0297	Spindle	S.Steel	2
Y-S0308	Stud	S.Steel	3
Y-S0310	Teflon pin	Teflon	1
Y-X0044	Compression spring	S.Steel	2
Y-X0055	Screw	S.Steel	6
Y-X0093	Washer	S.Steel	3
Y-X0099	Compression spring	S.Steel	1
Y-X0163	Compression spring	S.Steel	1
Y-X0178	Screw	S.Steel	4
Y-X0718	Compression spring	S.Steel	1
Y-X0719	Screw	S.Steel	2
Y-X0814	Screw	S.Steel	1
Y-X0833	Nut	S.Steel	3
Y-X1074	Torsion spring	S.Steel	1

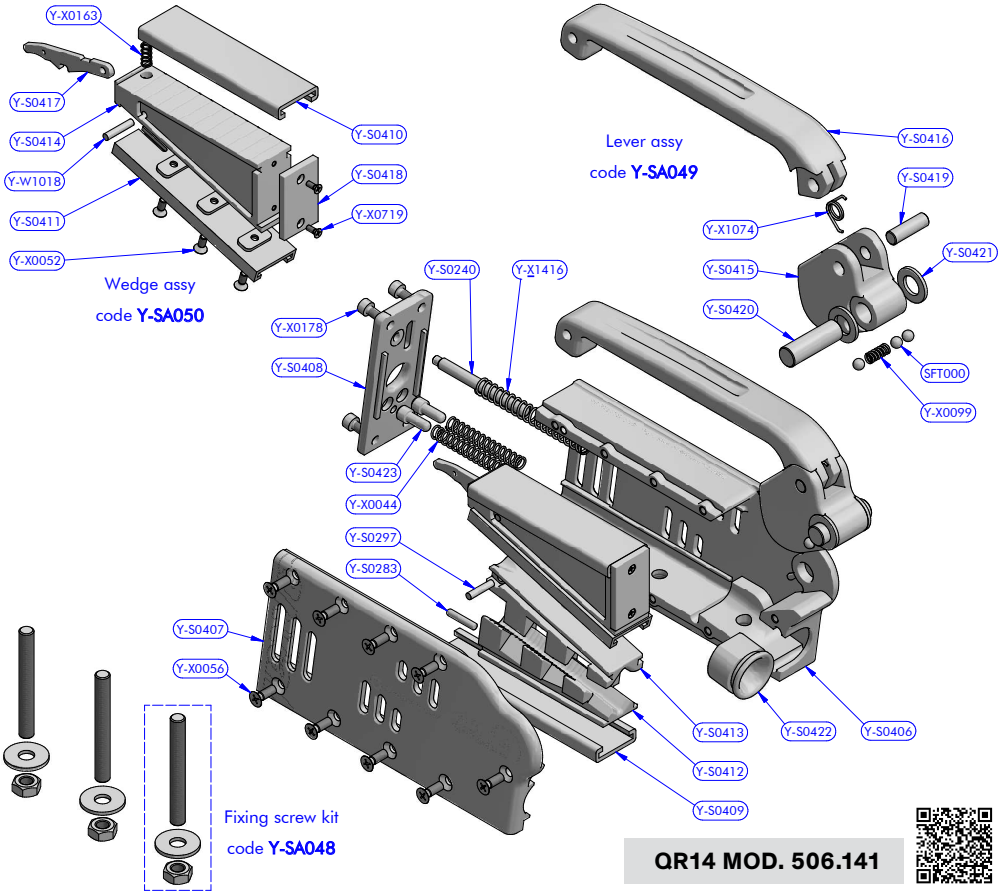

QR14 MOD. 506.141

PART LIST			
CODE	DESCRIPTION	MATERIAL	Q.TY
SFT000	Torlon ball 1/4"	Plastic	3
Y-S0240	Wedge spring pin	S.Steel	1
Y-S0283	Free line mark	Aluminium	1
Y-S0297	Spindle	S.Steel	1
Y-S0406	Body	Aluminium	1
Y-S0407	Cheekplate	Aluminium	1
Y-S0408	Rear cover	Aluminium	1
Y-S0409	Lower guide	Polietilene	1
Y-S0410	Upper guide	Composite fibre	1
Y-S0411	Middle guide	Polietilene	1
Y-S0412	n.d.	Aluminium	1
Y-S0413	Upper jaw	Aluminium	1
Y-S0414	Wedge	Aluminium	1
Y-S0415	Cam	Aluminium	1
Y-S0416	Lever	Aluminium	1
Y-S0417	Lock lever	S.Steel	1
Y-S0418	Pad	Composite fibre	1

PART LIST			
CODE	DESCRIPTION	MATERIAL	Q.TY
Y-S0419	Spindle	S.Steel	1
Y-S0420	Spindle	S.Steel	1
Y-S0421	Platic washer	Plastic	2
Y-S0422	Ring	Aluminium	1
Y-S0423	Spring pin	S.Steel	2
Y-SA048	Fixing screw kit	S.Steel	3
Y-W1018	Spindle	S.Steel	1
Y-X0044	Compression spring	S.Steel	2
Y-X0052	Screw	S.Steel	3
Y-X0056	Screw	S.Steel	9
Y-X0099	Compression spring	S.Steel	1
Y-X0163	Compression spring	S.Steel	1
Y-X0178	Screw	S.Steel	4
Y-X0719	Screw	S.Steel	2
Y-X1074	Torsion spring	S.Steel	1
Y-X1416	Compression spring	S.Steel	1



www.antal.it